

SAV709 Stainless Steel Chain

SAV709 chain was designed as an economical stainless steel chain alternative to Non-Metallic and Cast Chain for rectangular clarifier usage. Maintaining the same materials and design as SAV715, the primary difference between the two chains is the SAV709 chain's ability to run on standard 720 series sprockets. The chain can be used with fiberglass or wooden flights. No special modifications to the existing system or tank layouts is required.

- 403 Stainless Steel
 - Direct Interchange with
 - 720 Non-Metallic and Cast
- Chains Lightweight (2.2 Lbs)
- „J” Cotter Assembly

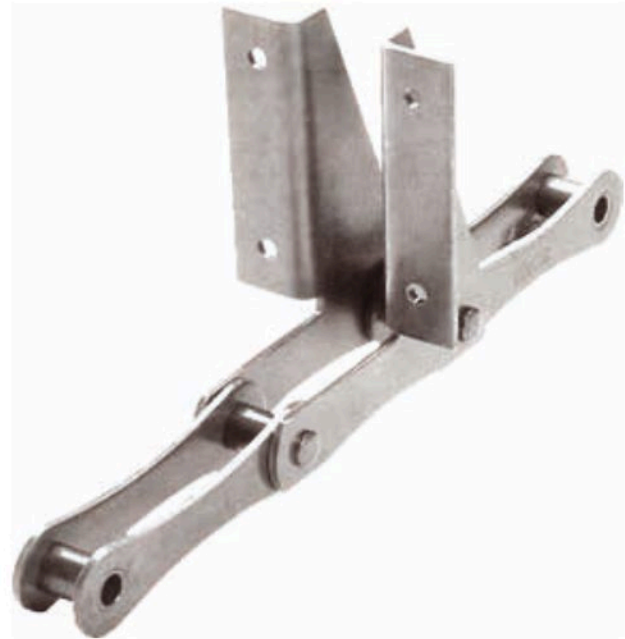

SAV 709 Key Features

Average Ultimate Strength of 19,000 lbs. makes the SAV709 comparable to even high strength composite chains. The 403 stainless steel material has over 35 years of proven experience in wastewater treatment chain applications. Special manufacturing processes provide a chain with unmatched resistance to abrasion and corrosion resulting in extended service life. The light weight offers ease of installation and requires very little maintenance. SAV709 can be used with Non-Metallic, steel or cast iron sprockets

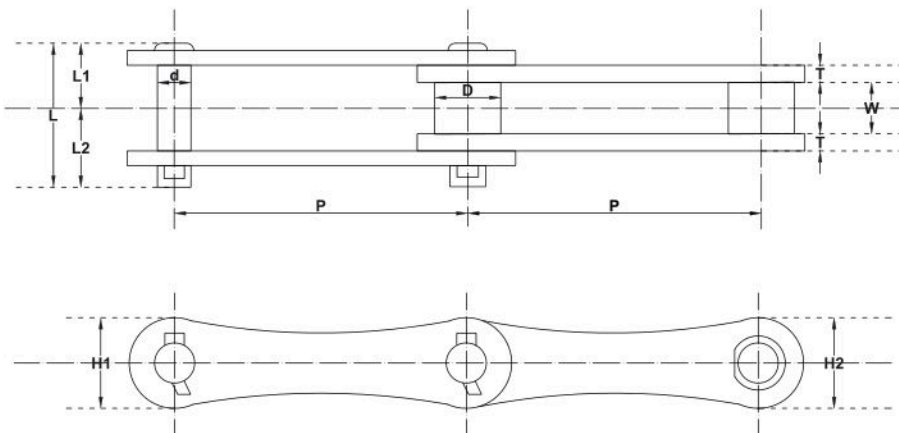

Chain No.	Units	Pitch P	Average Ultimate Strength	Weight	Barrel		Pin			Side Bars				
					Outside Dia. D	Width W	Dia. d	Length			Pin Link		Bushed Link	
								L	L1	L2	H1	T	H2	T
SAV 709	inch	5,844	19000 lbs	2,2 lbs/ft	0,882	1,265	0,453	2,578	1,171	1,406	1,218	0,187	1,453	0,187
	mm	148,44	84,52 kN	3,27 kg/m	22,40	32,13	11,51	65,48	29,74	35,71	30,94	4,75	36,91	4,75

SAV709 Stainless Steel Chain

SAV709 chain with standard F-226 or F-228 attachment links provides a strong solution for difficult collector operations. Pictured here is SAV709 with Terson's HMAX Extreme Duty FRP Flights. The tank width is over 36 ft long and handles primary sludge. The plant elected to replace mechanical travel bridge units (visible in background) and discovered that the superior strength and capability of the SAV709 made it the ideal choice. Typical clarifier design is limited at around 30 ft. width with plastic chain, which would have necessitated the costly prospect of creating two clarifiers out of the original one. SAV709 and the HMAX flights allowed the plant to retain the original layout, saving the plant from a significant expense.



36 ft wide Clarifier - SAV709 Chain with HMAX Extreme Duty Flights



Closer view - 36 ft wide Clarifier with SAV 709 Chain

- Strong - Lightweight
- Versatile in application
- Cost Effective Solution

SAV 709 „F” Style Attachment Link

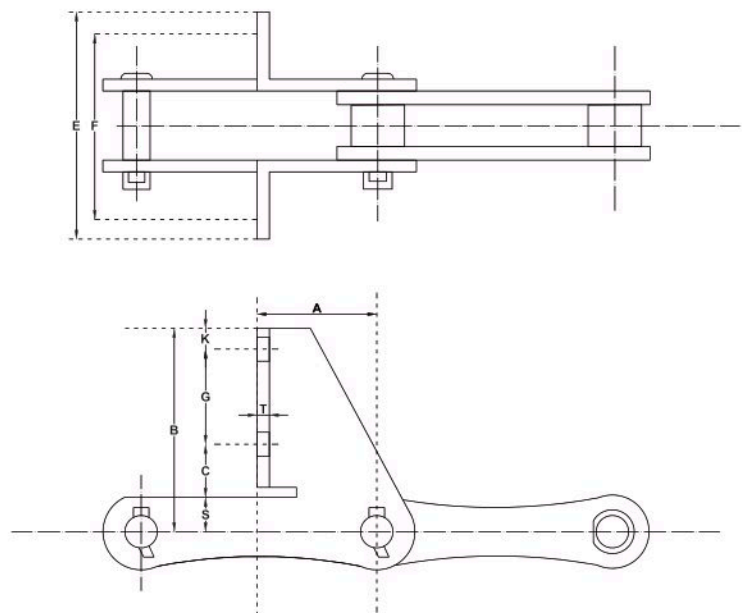

Dimensions of SAV 709 Stainless Steel Chain (F Attachment)

Attachment Part No.	Units	Dimension										Attachment Nominal Weight
		A	B	C	E	F	G	K	S	T	Ø	
F-226/709	inch	2,913	6,5	1,640	5,5	3,75	2,625	1,234	1	0,187	0,437	3,9 lbs/ea
	mm	73,99	165,10	41,66	139,70	95,25	66,68	31,34	25,40	4,75	11,10	1,77 kg/pcs
F-228/709	inch	2,913	8,265	1,640	5,5	3,75	4,5	1,125	1	0,187	0,437	4,5 lbs/ea
	mm	73,99	209,93	41,66	139,70	95,25	114,30	28,58	25,40	4,75	11,10	2,04 kg/pcs